

GAS STAY LIFT PD-LIFTNEW

LIFTS

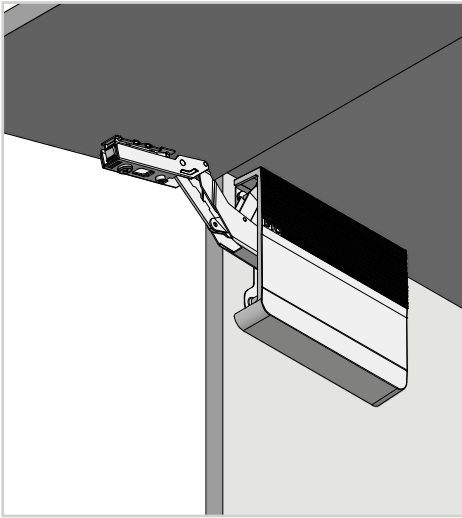

APPLICATION



CHARACTERISTICS



PACKING



SET INCLUDES

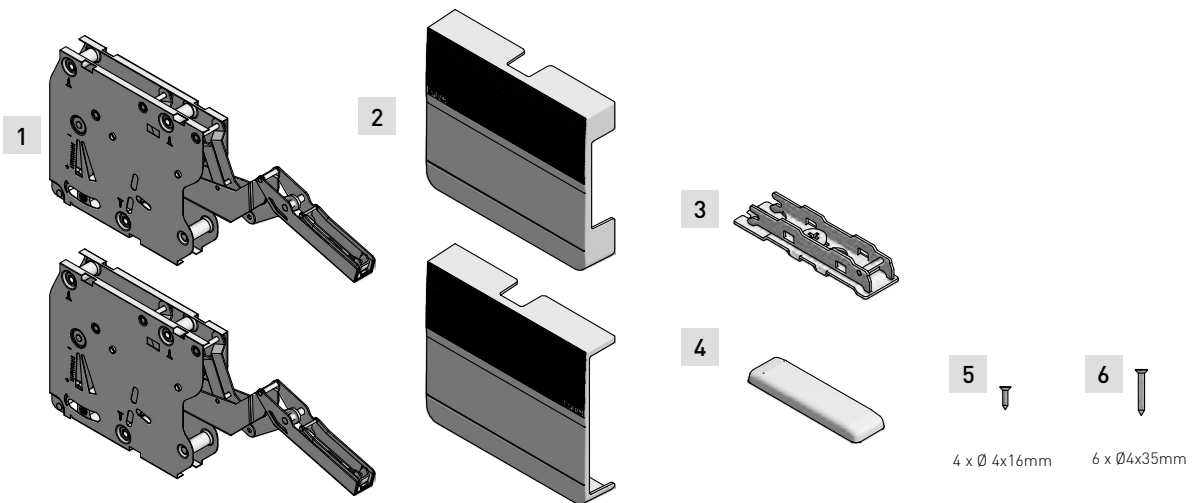

Cabinet planning information

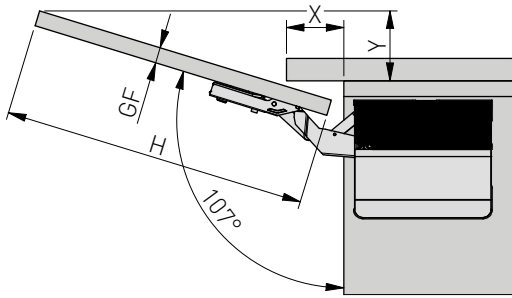

GF (mm)	16	19	22	26	28
X (mm)	70	58	48	35	26
Y (mm)	$Y = H \times 0,29 - 15 + GF$				

Spacing of mounting holes in the body and on front

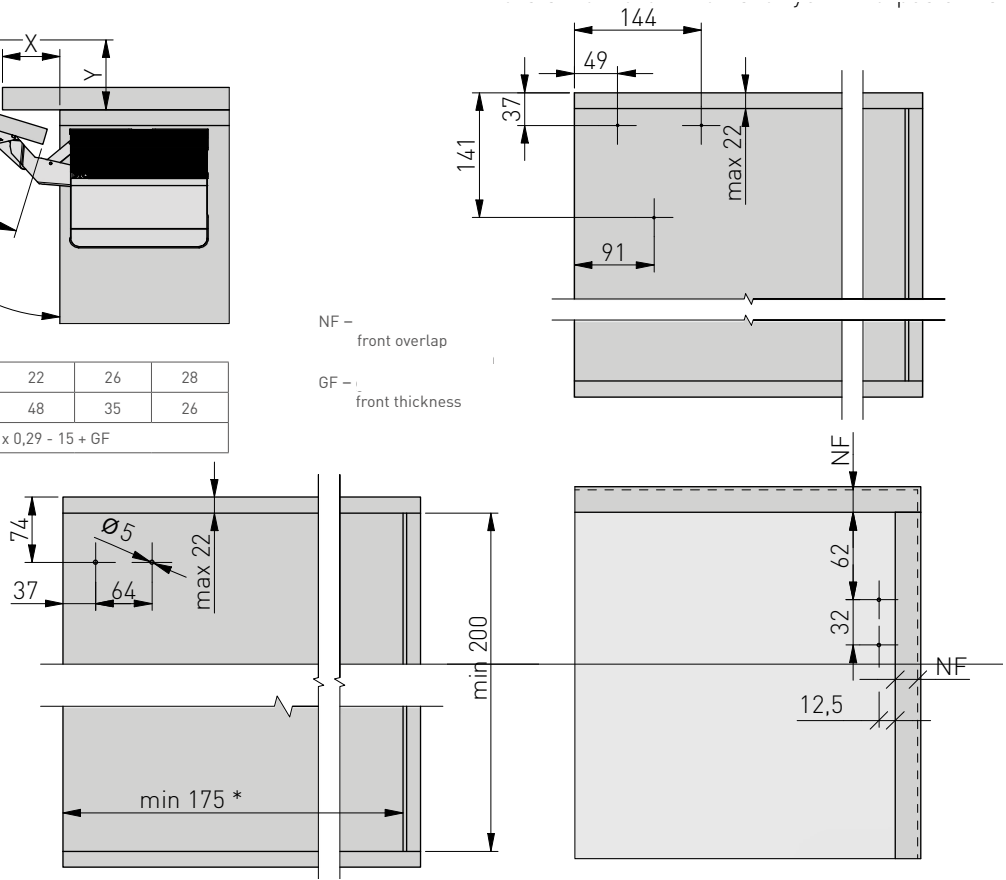

* for mounting with hanger min. = 240

Product dimensions

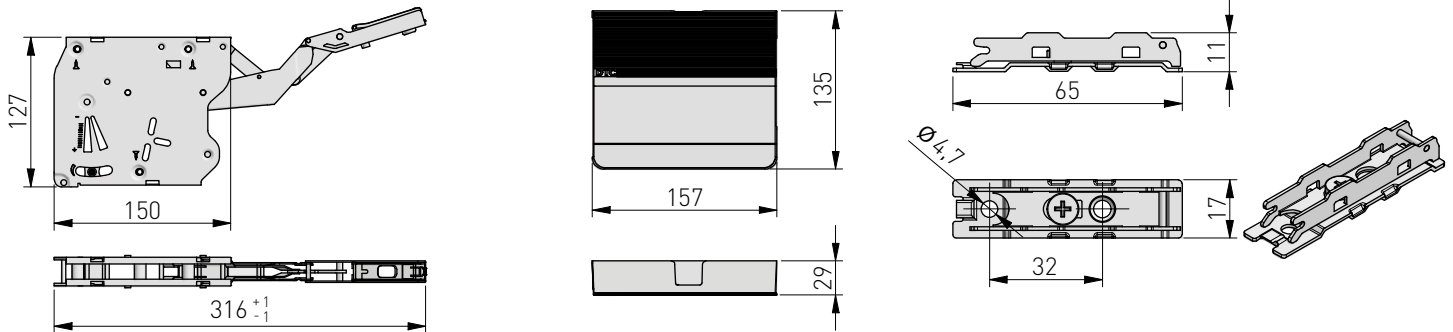

ASSEMBLY

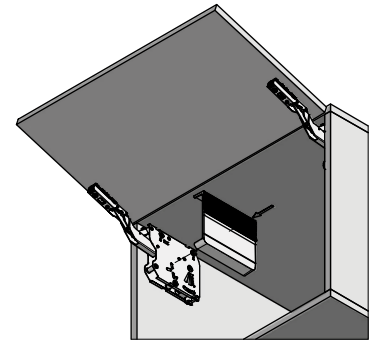
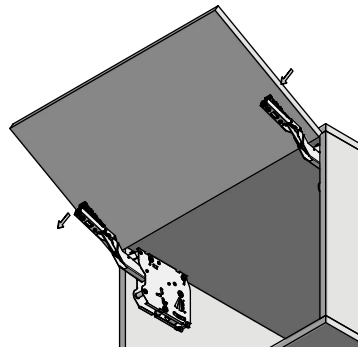
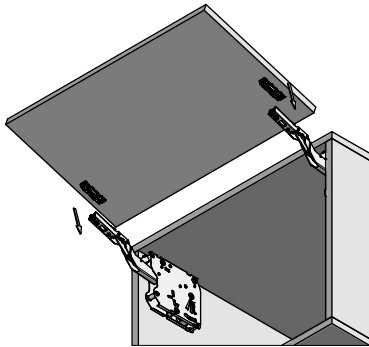
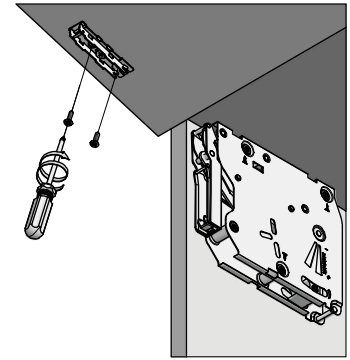
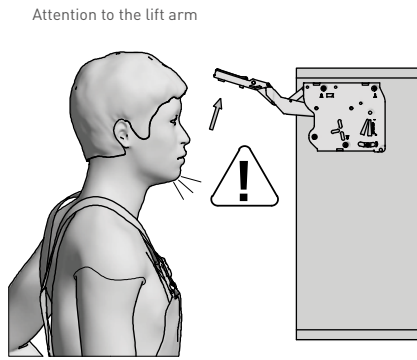
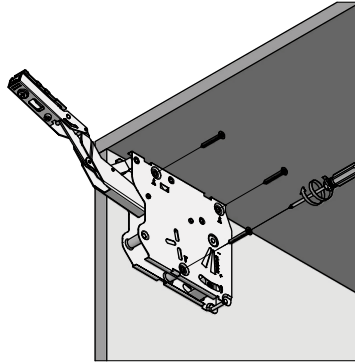

ADJUSTMENT

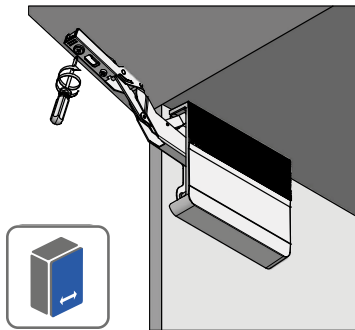

± 2 mm

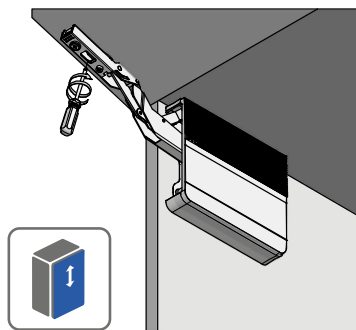

± 2 mm

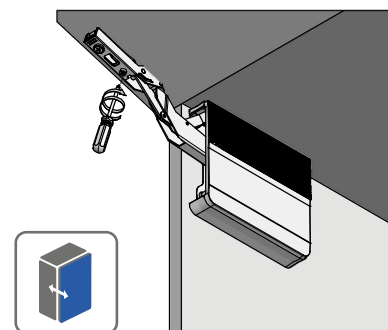

± 2 mm

OPENING FORCE ADJUSTMENT

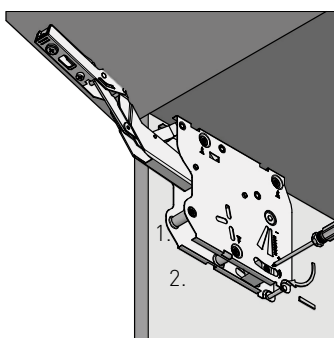

1. Main adjustment
2. Precision adjustment

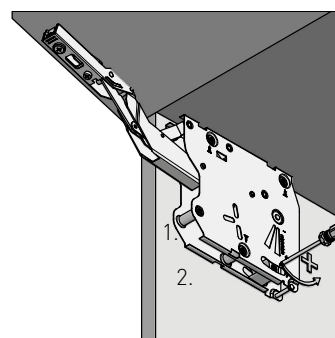
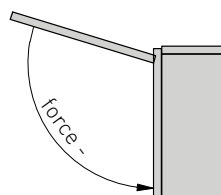

1. Main adjustment
2. Precision adjustment

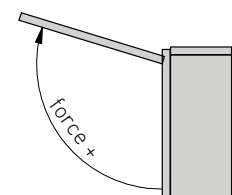

ANGLE STOP INSTALLATION

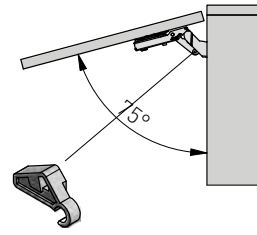
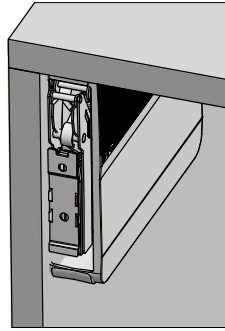
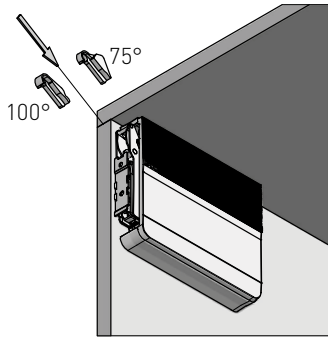

PD-LIFT-OG75

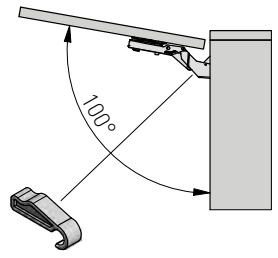

PD-LIFT-OG100

REMOVAL

