



www.hafele.com

#W1D





732.23.014

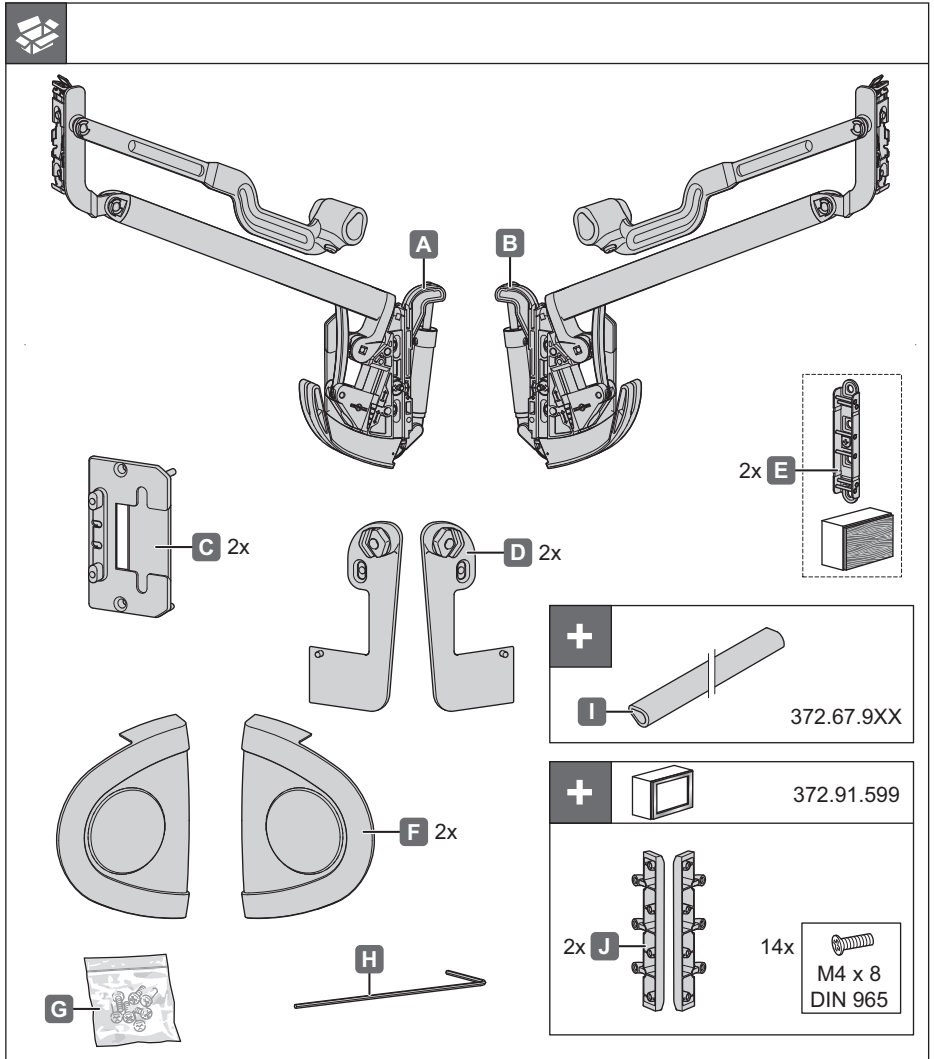

12.0001.010.388.0000.00

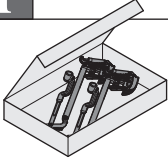
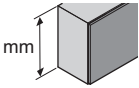
HDE 25.06.2013

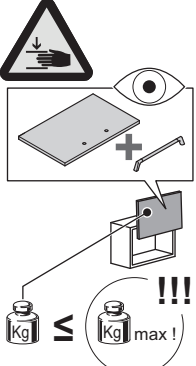

<b>i</b>			
			
	342 - 420	1,5 - 4,0 kg	372.68.831
		4,0 - 7,2 kg	372.68.832
		6,5 - 11,5 kg	372.68.833
	420 - 500	2,0 - 3,5 kg	372.68.801
		3,5 - 7,0 kg	372.68.802
		6,5 - 11,0 kg	372.68.803
	500 - 550	8,0 - 16,0 kg	372.68.804
		3,8 - 10,0 kg	372.68.813
	550 - 650	6,0 - 15,0 kg	372.68.814
		3,5 - 10,0 kg	372.68.823
		6,0 - 14,5 kg	372.68.824

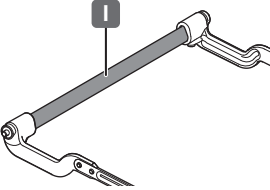
732.23.014

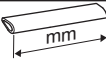
<b>i</b>				
				
	600	16 19	477	372.67.983
	900	16 19	777	372.67.985
	1200	16 19	1077	372.67.987
	1500	16 19	1377	372.67.989
	1800	16 19	1677	372.67.990

12.0001.010.388.0000.00

HDE 25.06.2013

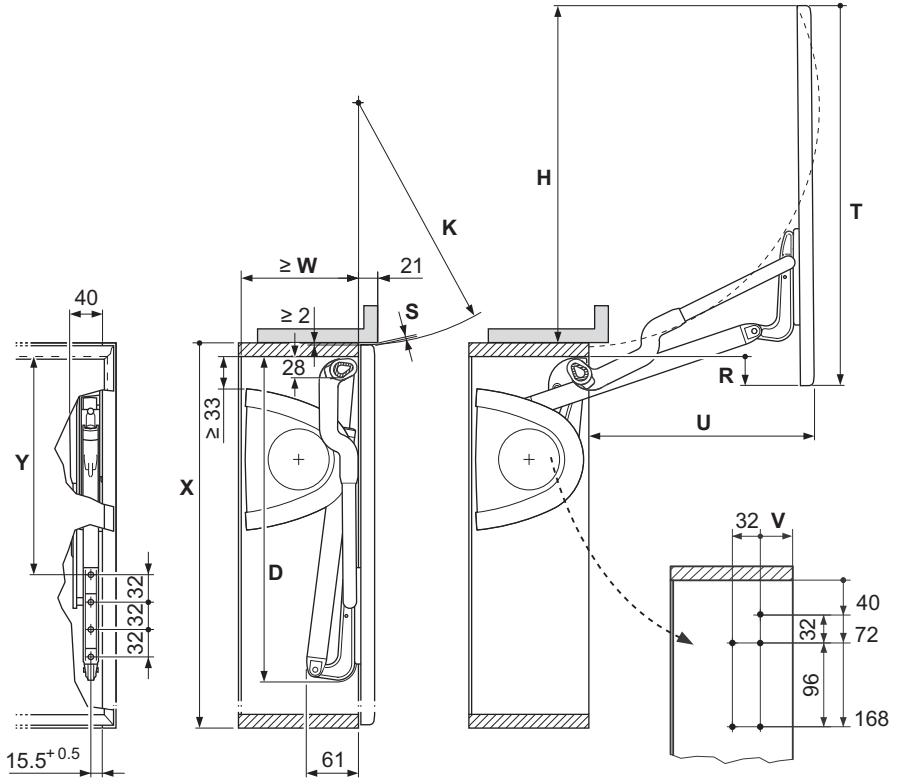

mm	X	Y	D	H	K	R	S	T	U	V	W
				ca.		ca.			ca.	min.	
342 - 420	342	186	308	295	205	28	0,8	338	200	50	151
	350	186	308	295	205	36	0,8	346	200	50	151
	420	186	308	295	205	98	0,8	416	200	50	151
420 - 500	420	255	380	395	271	5	1,2	414	265	37	138
	450	255	380	395	271	35	1,2	444	265	37	138
	500	255	380	395	271	85	1,2	494	265	37	138
500 - 550	500	293,5	420	450	312,5	30	1,3	494	295	37	138
	550	293,5	420	450	312,5	80	1,3	544	295	37	138
	550	313,5	440	480	332,5	50	1,3	544	315	37	138
550 - 650	600	313,5	440	480	332,5	100	1,3	594	315	37	138
	650	313,5	440	480	332,5	150	1,3	644	315	37	138

732.23.014

12.0001.010.388.0000.00

HDE 25.06.2013

1



5 mm



9 mm



mm

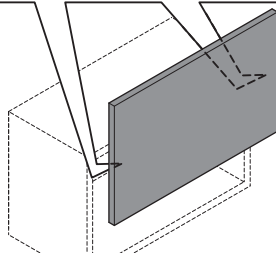
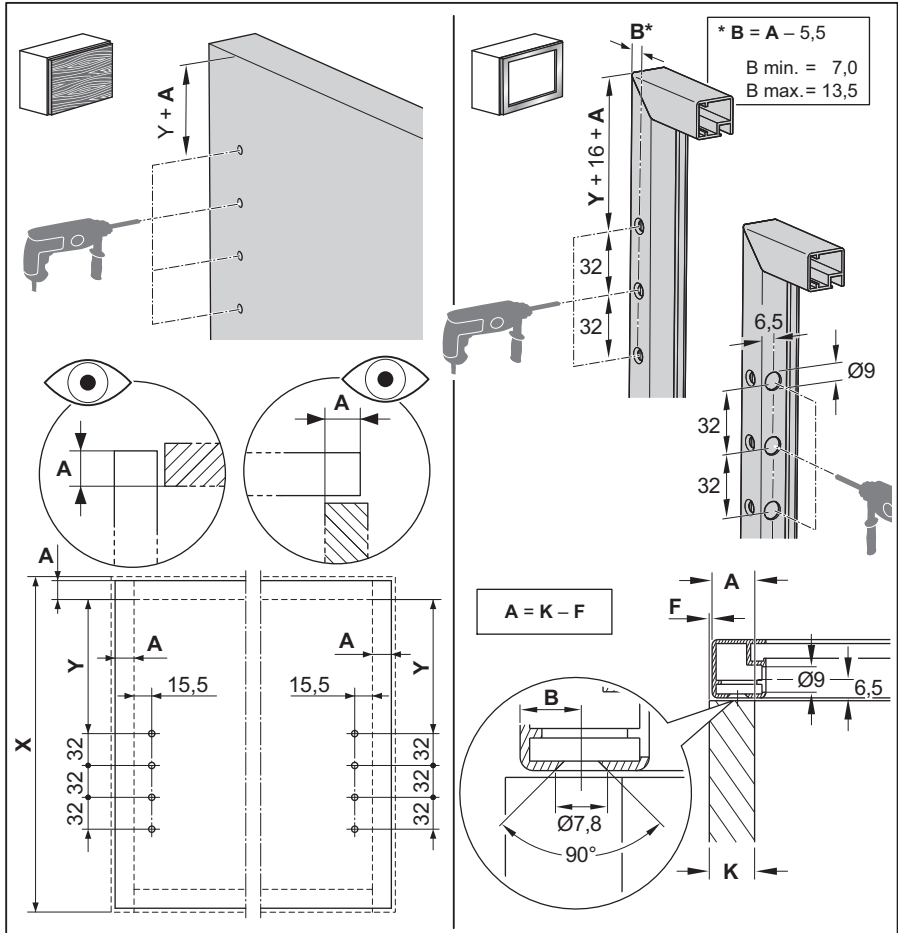

X	Y
342 - 420	186
420 - 500	255
500 - 650	293,5
550 - 650	313,5

732.23.014

12.0001.010.388.0000.00

HDE 25.06.2013

2

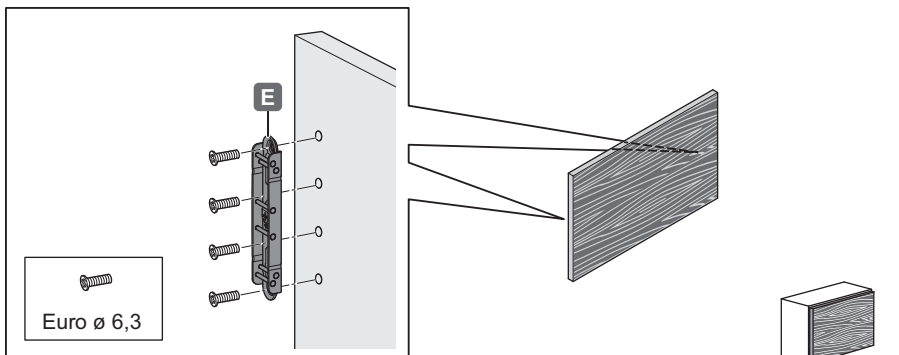

732.23.014

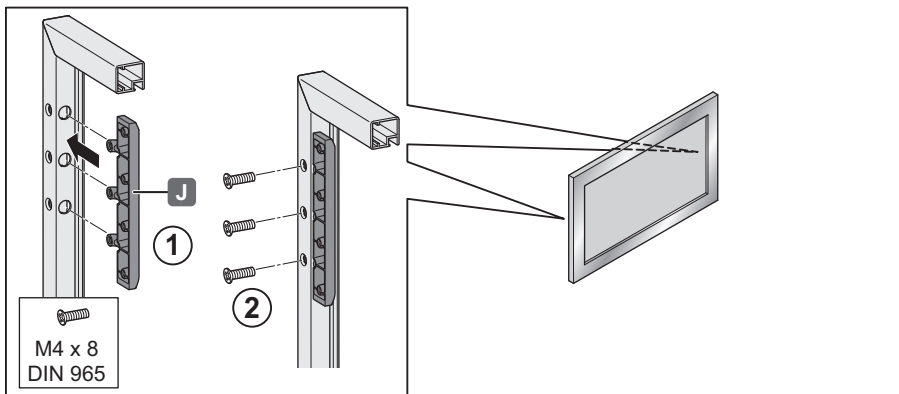

12.0001.010.388.0000.00

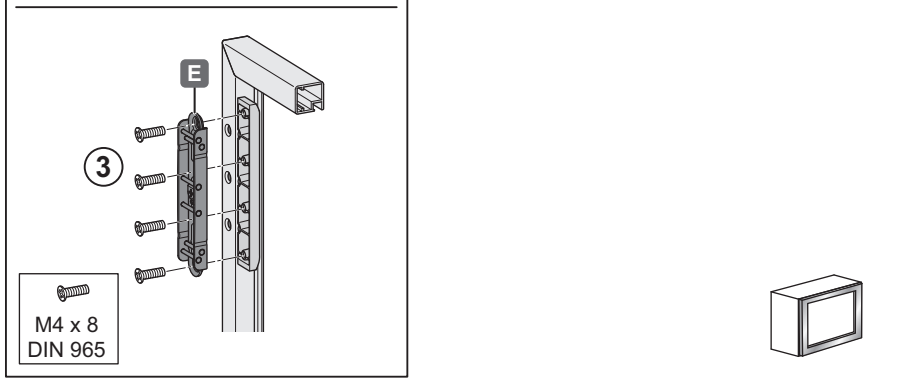

HDE 25.06.2013

3

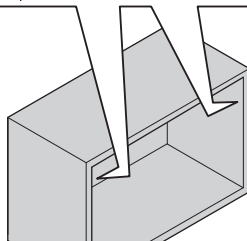
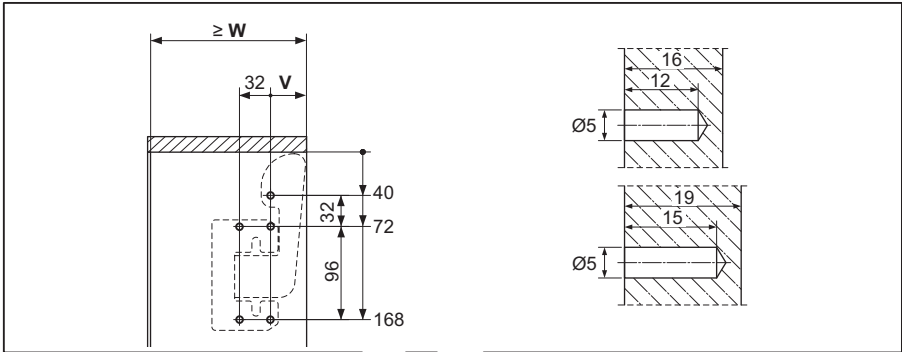

mm	V	W min.
342 - 420	50	151
420 - 650	37	138

732.23.014

4

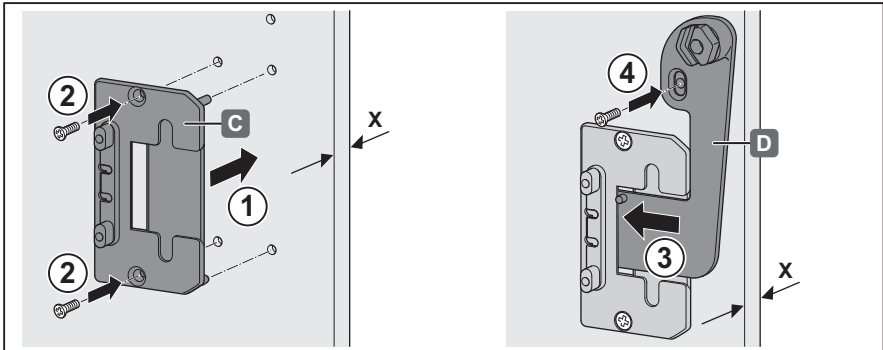

X	
16	Euro ø 6 x12
19	Euro ø 6 x16

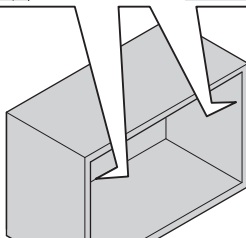

12.0001.010.388.0000.00

HDE 25.06.2013

5



PZ 1/2

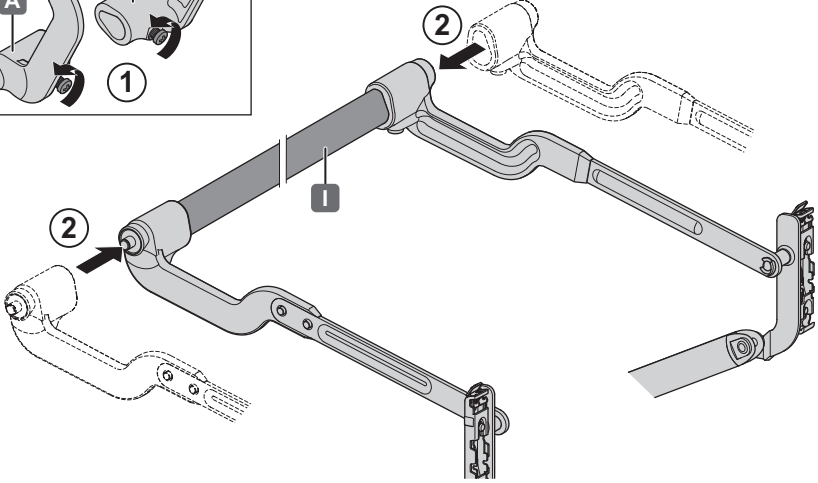
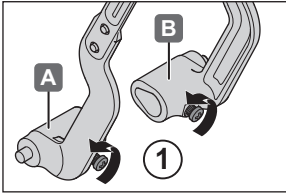

732.23.014

6

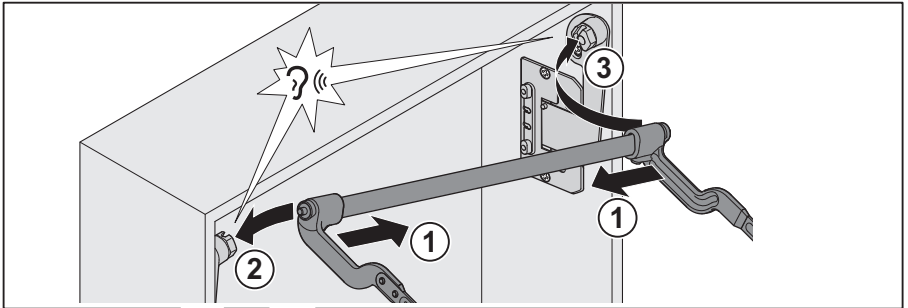

12.0001.010.388.0000.00

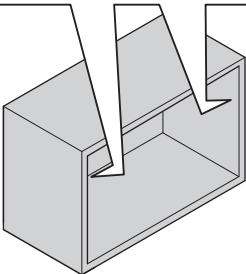

HDE 25.06.2013

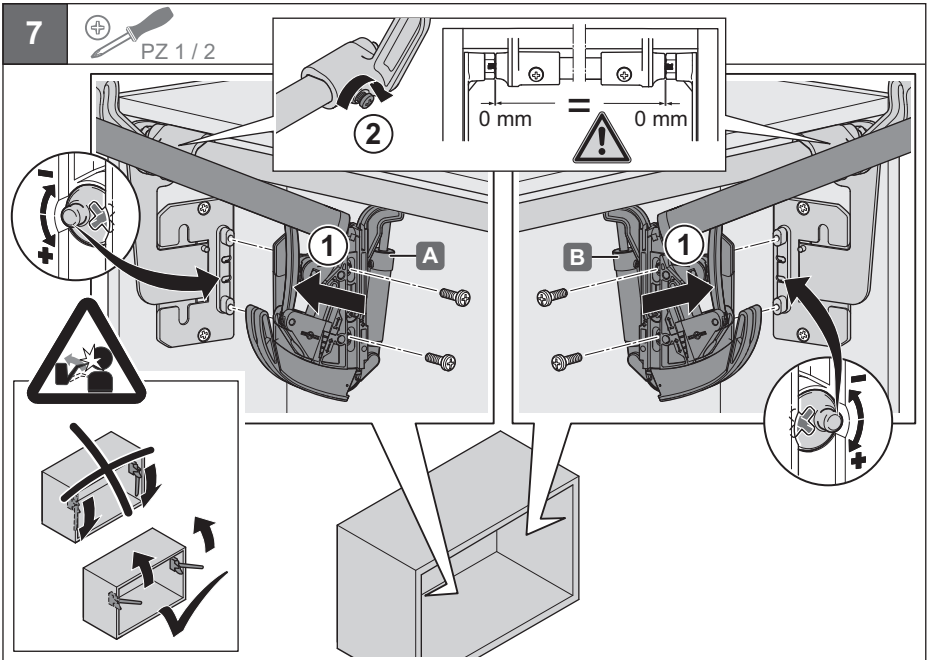

732.23.014

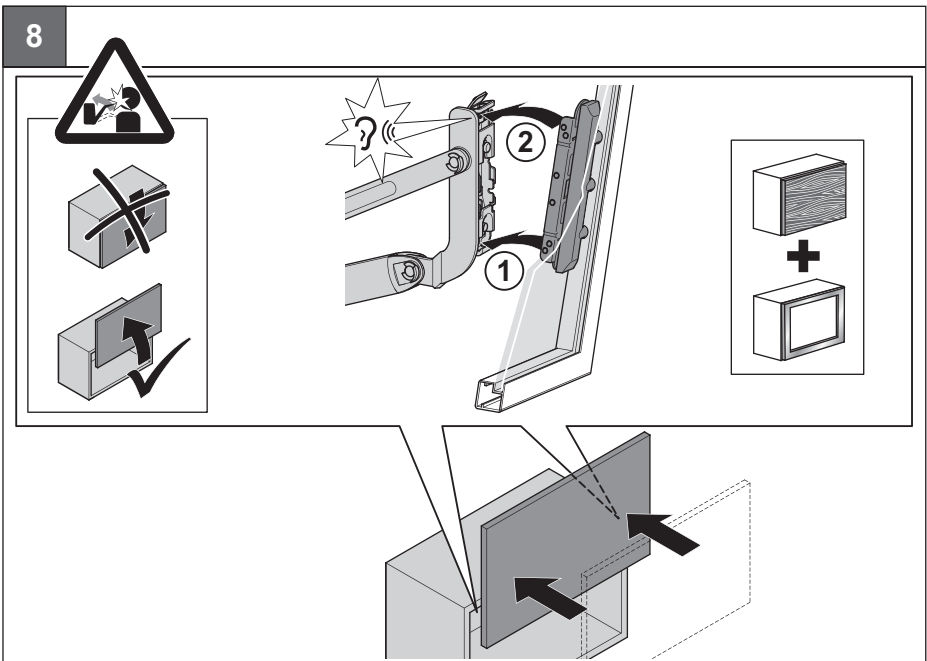

12.0001.010.388.0000.00

HDE 25.06.2013



9

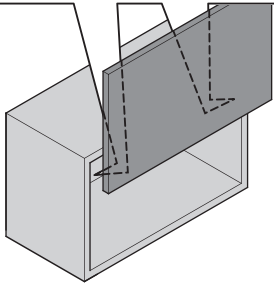
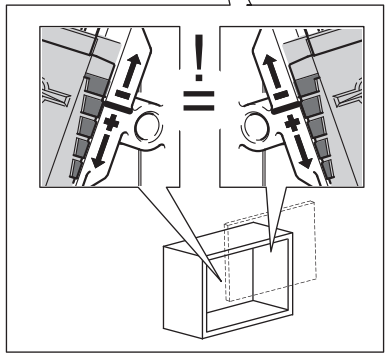
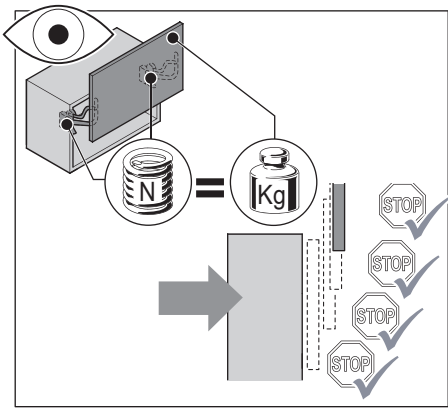
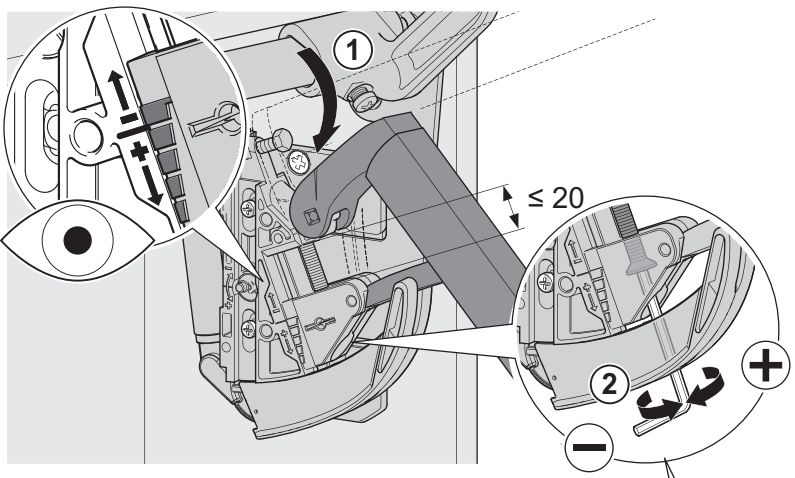

732.23.014

12.0001.010.388.0000.00

HDE 25.06.2013

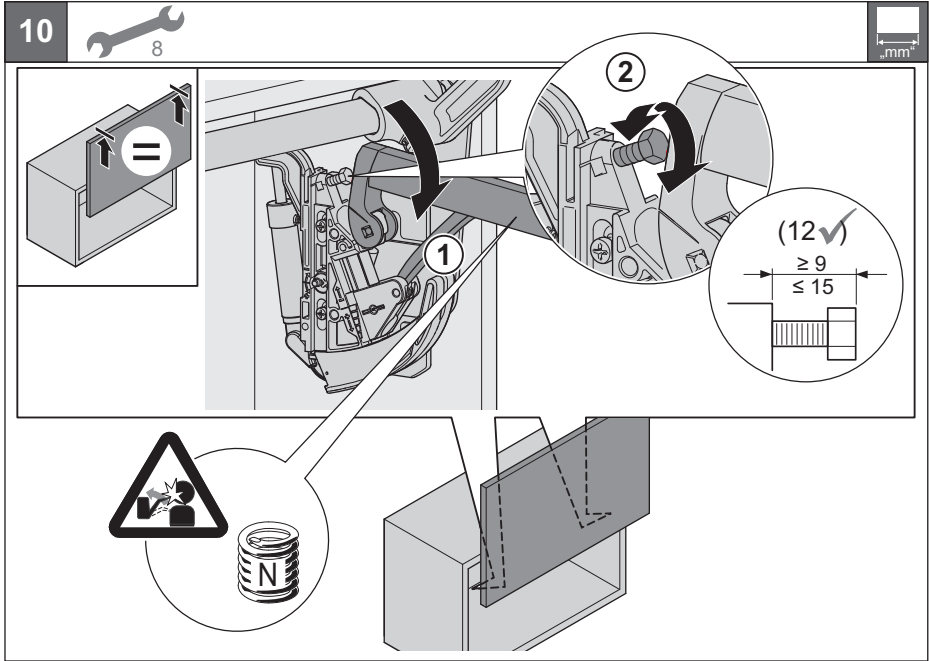

732.23.014

12.0001.010.388.0000.00

HDE 25.06.2013

12



PZ 1/2

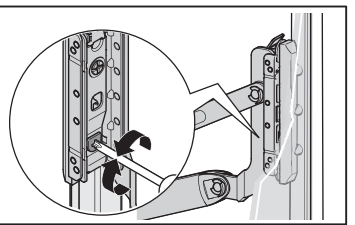
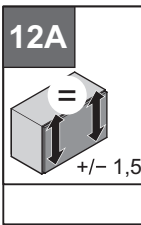
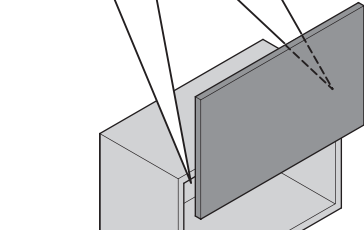
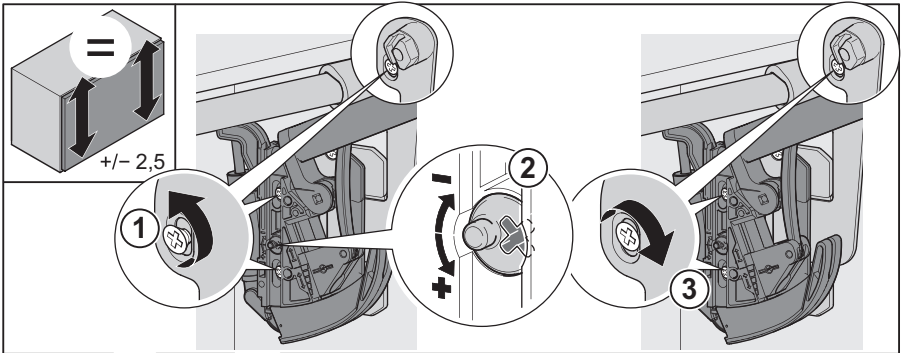

732.23.014

13



4



19



PZ 1/2

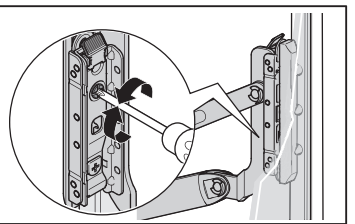
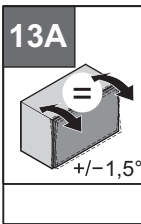
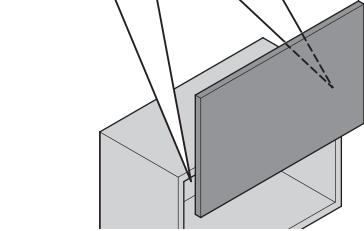
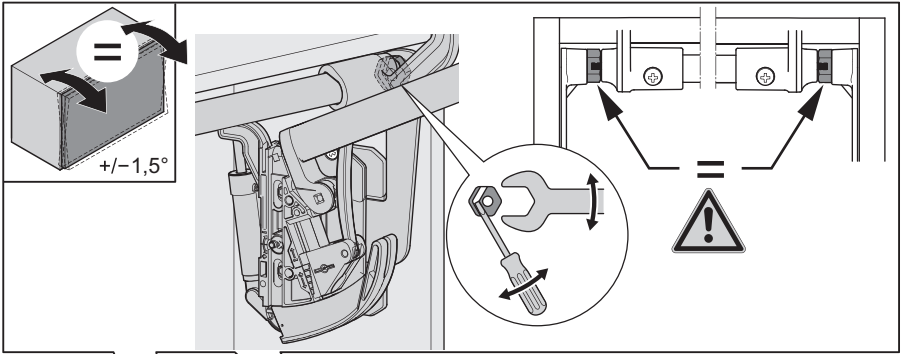

12.0001.010.388.0000.00

HDE 25.06.2013

14

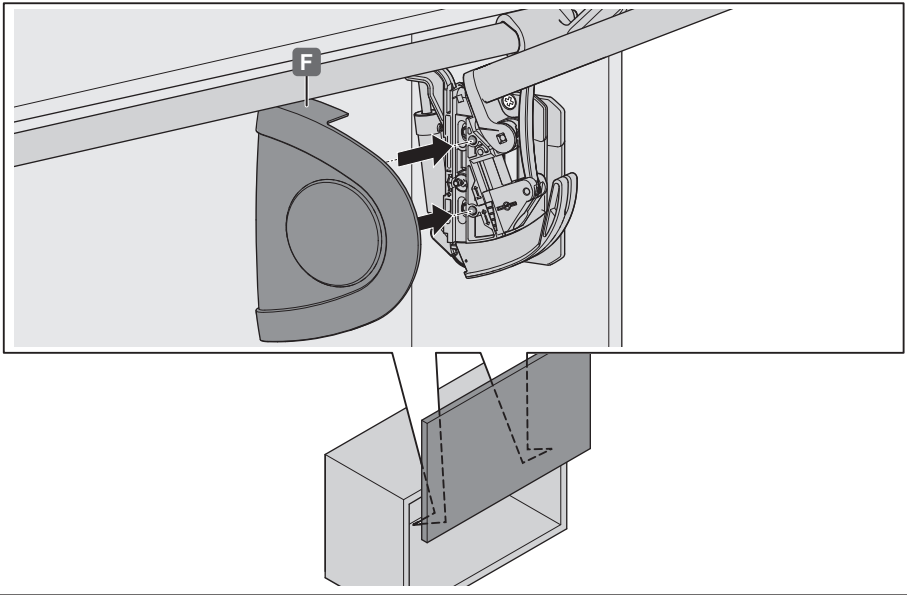

732.23.014

**i**

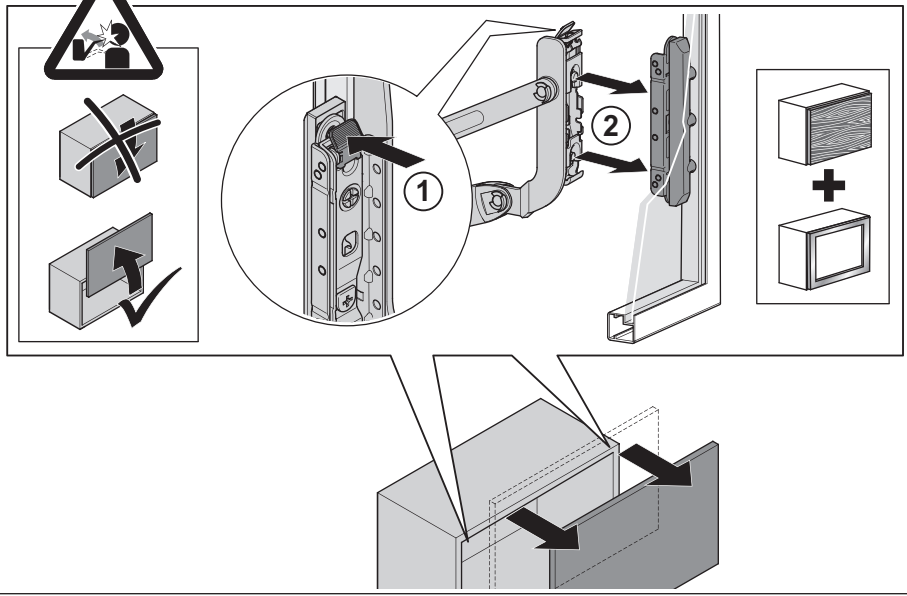

12.0001.010.388.0000.00

HDE 25.06.2013